

Spare parts list – Tormek T-8

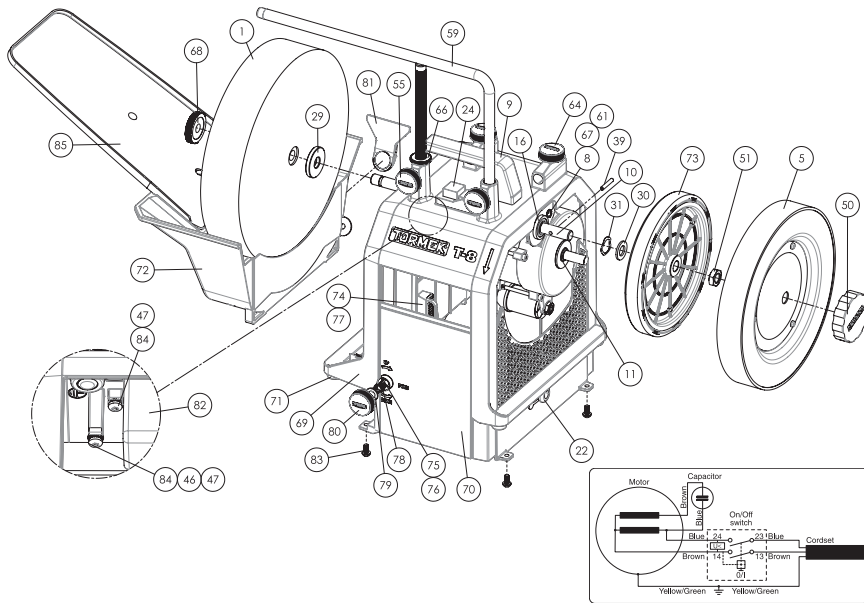

No.	Denomination	Qty	Part no.	No.	Denomination	Qty	Part no.
1	Grindstone	1	6011	55	Locking screw	2	7031
5	Honing wheel	1	0591-07	59	Universal Support excl. adjusting nut	1	0220
8	Mounting shaft	1	1015	61	* Distance spring for the motor	1	0561
9	Handle incl. nut and washer	1	3041	64	Locking screw	2	7120
10	** Main shaft	1	1041	66	Adjusting nut with scale	1	1162
11	Motor	1	6021 (230 V) 6161 (115 V)	67	* Bushing for mounting shaft	1	3123
16	Nylon bearing	2	3061	68	EzyLock	1	1190
21	* Cord set	1	6031 (SE) 6041 (CH) 6043 (US) 6050 (JP) 6053 (GB) 6055 (AU) 6057 (ZA)	69	Housing	1	2000
22	Cord set bushing	1	6081 (230 V) 6191 (115 V)	70	Plastic cover	1	3070 (230 V) 3130 (115 V)
24	Switch	1	6320 (230 V) 6330 (115 V)	71	Rubber foot	4	3198
29	Washer for the stone	1	0130	72	Water trough	1	3090
30	Washer for the drive wheel	1	5081	73	Drive wheel with friction ring	1	2010
31	Wave spring washer	1	5410	74	Water trough holder	1	2020
39	Locking pin	1	5071	75	Gear shaft	1	2070
46	Folded washer	2	5001	76	Locking head	1	2080
47	Locking washer	3	5021	77	Guide rail	2	3110
50	Locking knob for honing wheel	1	7041	78	Spring	1	0800
51	Nut. M12 h=4	1	1051	79	Washer 8.4×15×1.6 mm	1	5020
				80	Knob water trough	1	7005
				81	Scraper water trough	1	3100
				82	Cover for switch	1	3080
				83	Screw M5×10 mm	4	5590
				84	Screw M4×8 mm	3	5600
				85	Water chute	1	3510

* Not shown on drawing.

** Available only with MSK-250.

Weight machine only: 14.8 kg (32.6 lbs)